

COMMERCIAL WASTE - ABOVE GROUND



AREA OF APPLICATION

This technical information is valid for the use and laying of hot water-resistant Milford commercial waste above ground pipes and fittings made of PP Dia.32-Dia.160 with sockets, that are used as waste water lines inside buildings.

MATERIALS

DESCRIPTION

Polypropylene (PP), produced according to DIN EN 1451-1 respectively DIN 19560- 10, resistant to hot water, permanent low inflammability as per DIN 4102 B1.

APPLICATION

Building drainage as:

- Waste water pipe
- Rainwater pipe
- Ventilation pipe

(also see areas of use: DIN 1986-4)

COLOUR

Dusty grey RAL 7037 and cadmium-free.

SEAL

Factory inlaid lip seal.

CHEMICAL RESISTANCE

Discharge of aggressive media in the range of pH 2 to pH 12.

MARKING (A)

Permanent marking with manufacturer label, nominal diameter, DIN standard (DIN EN 1451-1), date of manufacture, (fittings also marked with details).

SEALS

Company label of the sealing ring manufacturer, nominal diameter, DIN standard (DIN EN 681), date of manufacture, number of the mould and mould cavity.

MECHANICAL AND THERMAL PROPERTIES				
Property	Measuring method		SYMBOL	VALUE
Density (g/cm ³)	ISO R 1183	DIN 53 479	ρ	0,95
Notch impact resistance* as per Charpy (kJ/m ²)	ISO R 179 Test bar as per Fig. 2	DIN 53 453 Standard small bar	a_k	6,86
Limit bending stress (N/mm ²)		DIN 53 452 Standard small bar	σ_{bG}	43,14
yield stress (N/mm ²)	ISO R 527 Test speed C Test bar as per Fig. 2	DIN 53 452 Test speed V Test bar 4	σ_s	30,39
Tear resistance (N/mm ²)			σ_R	39,22
Elongation at tear (%)			ϵ_R	800
Modulus of elasticity (N/mm ²)		DIN 53 457 Section 2.3	E	1275
Vicat softening point (°C)	ISO R 306-1 kp	DIN 53 460 Method A Silicone oil	VSP/A	158 – 164**
Thermal conductivity (W/Km)		DIN 52 162	λ	0,22
Linear coefficient of thermal expansion (°C ⁻¹)		VDE 0304 Teil 1.4	α	$1,2 \cdot 10^{-4}$

* measured at 20°C

** applies to base material

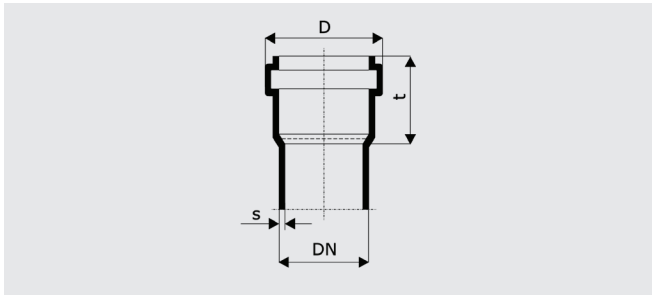

DN(OD)	s [mm]	D [mm]	t [mm]
32	1,8	44	40
40	1,8	53	55
50	1,8	63	56
75	1,9	88	61
110	2,7	125	76
160	3,9	181	90

TRANSPORT, HANDLING AND STORAGE

Unpalletized pipes should be laid completely flat along their entire length during transport. Heavy shocks – especially in freezing temperatures – must be avoided. Pipes and fittings may be stored outdoors; pre-installed sealing elements should not be stored longer than three years.

The following points must be observed when laying pipes:

- a) Pipes must be stored in a stable position so that no deformation or sagging can take place.
- b) The pipe sockets must be free, both in the vertical and horizontal directions.
- c) A stacking height of 1.5 meters should not be exceeded.

INSTALLATION

CUTTING TO LENGTH AND BEVELLING

Cutting pipes to length is done at right angles by using a pipe cutter or a fine-toothed saw. The cut edges must be deburred. The pipe end is then bevelled with a beveling tool or by using a coarse file at an angle of approx. 15° as shown in the following figure.

BEVELLING DIMENSIONS						
DN	32	40	50	75	110	160
b[mm]	3,5	3,5	3,5	3,5	4,5	6,0

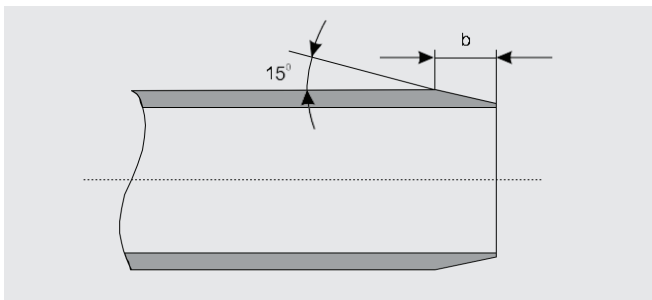
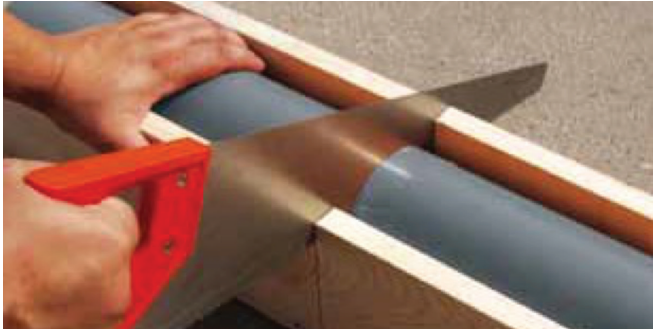

CONNECTING PIPES AND FITTINGS

a) Clean the pipe spigot end and clean the socket.



b) Check the condition and quality of the factory pre-installed ring seal.

c) Apply factory supplied lubricant lightly and evenly on the bevelled surface only of the spigot end.



When inserting, the ring seal must be free of lubricant. Center up the spigot end of the pipe and push until the pipe end reaches the end of the socket.

It is required that the pipe be pulled back a maximum of 10 mm. For normal HT pipes, that means a maximum length of 2 meters.

The spigot ends of fittings may remain fully pushed into the socket.

Pipes must be secured with pipe clamps to prevent slippage during subsequent installation work. This is done after taking into account the necessary measures concerning length changes.

MOUNTING

Pipe Clamps

In general, plastic waste water pipe systems must be installed so that they are not under mechanical stresses and are allowed to undergo natural length changes. As a rule, securing pipes is done with pipe clamps that have an inner lining and that are appropriate for the given outer diameter and which completely circumvent the pipe. If no inner lining is used inside the clamp, then the inside edge of the clamp must be rounded off and the inside surface must be smooth. Only an inner lining that is recommended by the pipe manufacturer can be used. Inner linings made of PVC or pipe hooks must not be used!

Fixed Clamps

Fixed points are achieved by completely tightening the pipe clamps in a piping system. They must be positioned so that each pipe length is prevented from slipping. The fixed clamps must be positioned directly behind the socket for pipe with sockets. Fittings or groups of fittings must always be laid out as fixed points.

Loose Clamps

Pipe clamps which are not completely tightened (loose clamps) must allow unimpaired longitudinal movement of the pipeline after installation. For this reason, the inside diameter of the clamp must be slightly bigger than the outside diameter of the pipe when installed.

Distance between Pipe Clamps

RECOMMENDED PIPE CLAMP INTERVALS		
DN	Horizontal [m]	Vertical [m]
32	0,50	1,2
40	0,50	1,2
50	0,50	1,5
75	0,80	2,0
110	1,10	2,0
160	1,60	2,0

LAYING

Laying Pipe Lines in Masonry Structures

Slots in masonry must be made to allow stress and tension free pipe installation. If the pipes must be embedded in mortar without the use of mortar carriers or enclosures, then the pipes and fittings must be completely wrapped in flexible material, such as cardboard, mineral or glass wool. At areas where high temperatures can occur, appropriate measures must be taken to protect the pipes (insulation of heat carrying lines e.g. heating lines).

Pipe Installation in Ceilings and Concrete Floors

Laying pipes in ceilings must be done so that they are moisture proof and sound proof. The appropriate wrapping material must be used. If fire protection requirements are placed on ceilings, then the appropriate fire protection steps are to be observed.

House waste water pipes and fittings may be embedded in concrete. Length changes of the pipes from thermal expansion must be considered as previously described. The parts of the pipe system must be fastened so that movement and expansion is prevented during concrete pouring. To prevent penetration of concrete fluid into the gaps of connections, an adhesive tape strip must be used to seal the socket joint. All pipe openings must be closed off.

CONNECTIONS

Connection to Pipes of Other Materials and Pipe Cuttings

To connect commercial waste pipes to other pipe system parts made of some other material, the appropriate fittings and sealing materials from the manufacturer must be used.

